

Installation & Operating Instructions for Tumo® Xcel Automated Drapery System

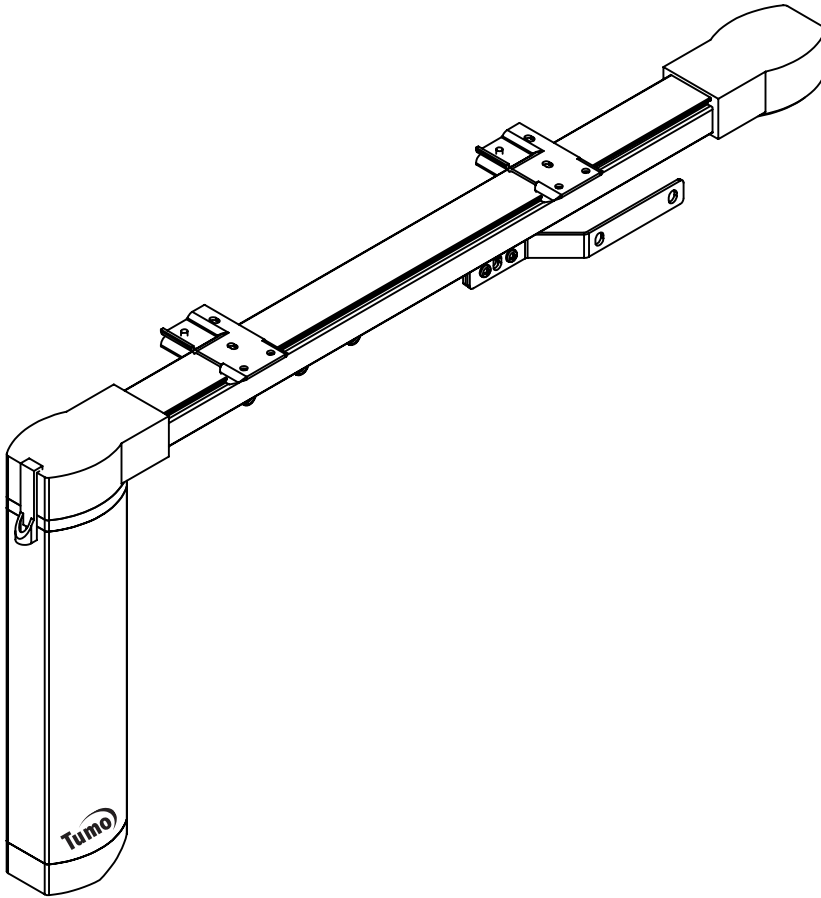





ENERGY SAVING PRODUCTS FOR
THE GREEN BUILDING MARKET

Tumo® Drapery System

Table of Contents

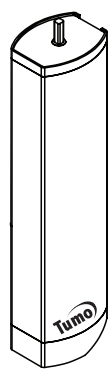
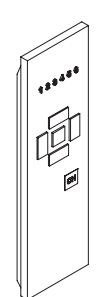
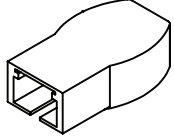
Tumo Xcel Automated Drapery Component List.....	4-5
Drive Runner Master Assembly Component List.....	6
Inventory Overview	7
Installing the Tumo Xcel with Ceiling Mount Brackets.....	8-9
Installing the Tumo Xcel with Wall Mount Brackets.....	10-11
Programming the Tumo Xcel.....	11-13
Operating the Tumo Xcel Drapery System.....	13
Low-Voltage Interface	14
Warranty/Terms & Conditions	15

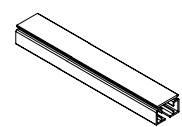
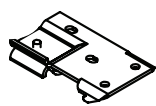
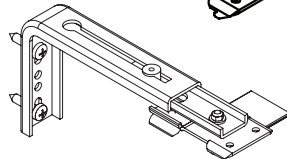
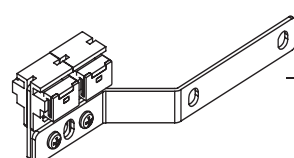

Component List

	Part #	Description
	101.9010	24V 12W DC Motor
	490.2075	6-Channel RF Handsender, Tumo Xcel Drapery
	266.5105	Drive Gear (2)
	266.5110	Gear End Cover Plate (2)
	310.6070	Headrail
	236.1610	Ceiling Mount Bracket (spacing/max 20 in)
	236.1865	Wall Mount Bracket w/ locking clip (spacing/max 20 in)
	266.4955	Drive Runner, master Assembly
	240.7505	Carriers, Swivel, 32-pack

Component List

Part #	Description
290.3005	Drive Belt
246.0650	Fabric Wrap Clip
240.7530	Cager
400.2300	Compact Plug-In Power Supply 110-240V AC input 24V DC output Cord length: 60" input from AC 60" output to motor
246.2220	Headrail Splice
480.3000 480.3005 480.3020 480.3025	Switch, Single, Low-Voltage, Almond Switch, Single, Low-Voltage, White Switch, Double, Low-Voltage, Almond Switch, Double, Low-Voltage, White

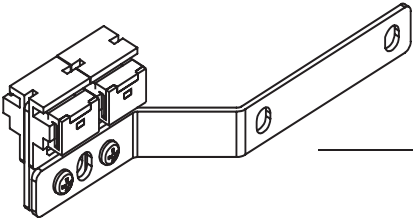
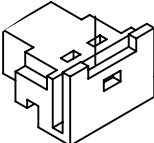
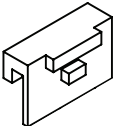
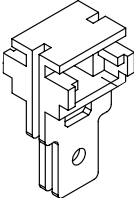
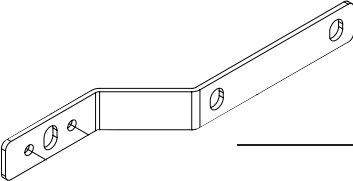
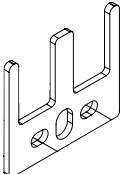
Component List for Drive Runner, Master Assembly

	266.4955	Drive Runner, Master Assembly
	250.5580	Belt End Socket
	246.0655	Belt End Clip
	240.7510	Lead Carrier
	240.7515	Lead Overlap Arm
	240.7520	Lead Carrier Connector
	240.7525	Overlap Arm Connector
	278.7025	Screw for Drive Runner Master Assembly

Installation Instructions

The Tumo Xcel Drapery System consists of:

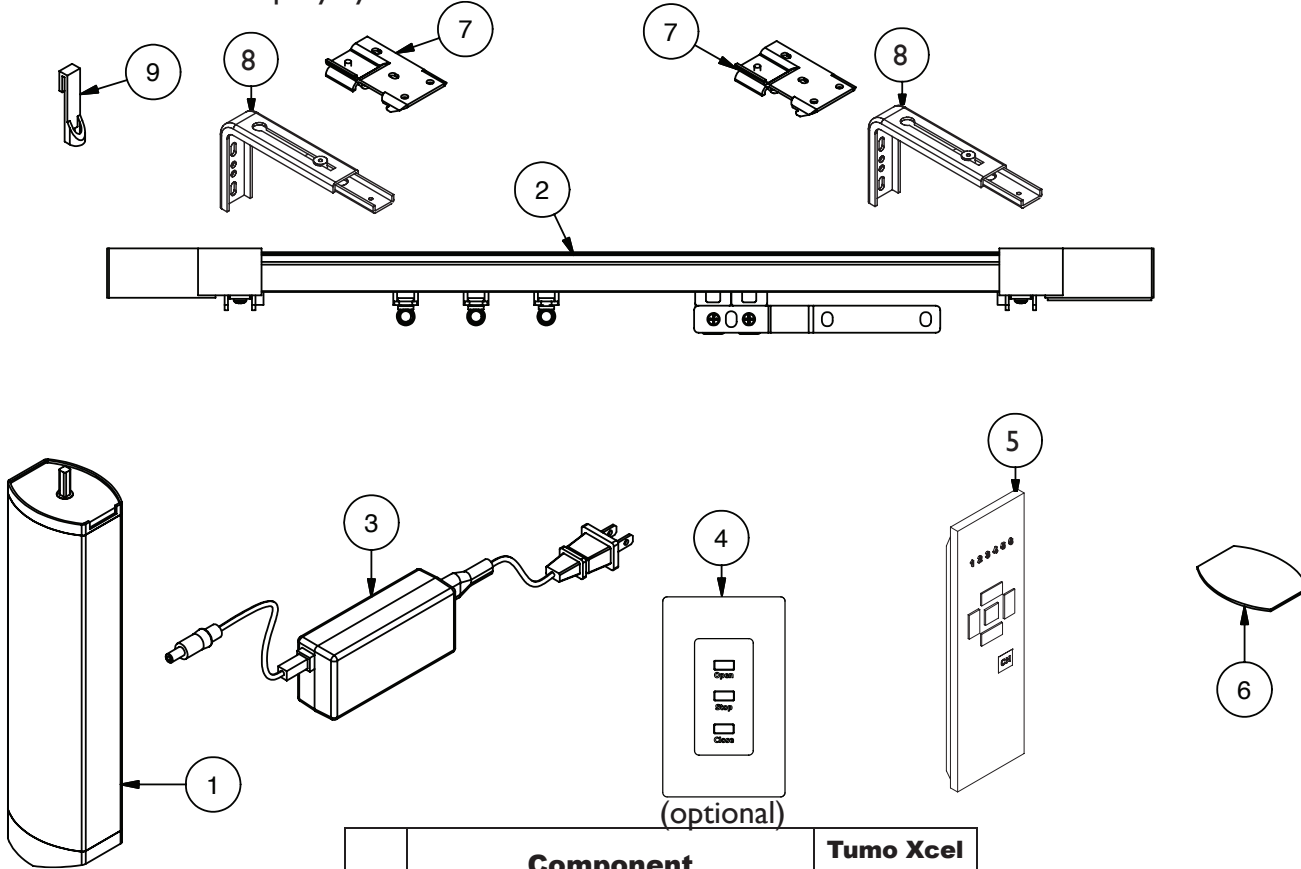

	Component	Tumo Xcel Drapery
1	Intelligent Motor	1
2	Silent Drapery Track	1
3	AC/DC Power Supply	1
4	Wall Switch	optional
5	Multi-Channel Handsender	1
6	Gear end Cover Plate	2
7	Track Mounting Bracket*	n
8	Wall Bracket*	n
9	Fabric Wrap Clip	2

Note: Required number of track mounting brackets

$n = \text{track length (inches)} / 20$

Number of Brackets = Track width divided by 20

*Brackets spacing is max 20 in.

- 1) Motor (101.9010)
- 2) Headrail Assembly (consists of: headrail (310.6070), drive belt (290.3005), drive gear (266.5105), drive runner master assembly (266.4955), carriers (240.7505), cagers (240.7530))
- 3) Compact Plug-In Power Supply (400.2300)
- 4) Wall Switch (480.30xx : contact factory for type and color)
- 5) 6-Channel Handsender (490.2075)
- 6) Gear End Cover Plate (266.5110)
- 7) Locking Mounting Bracket (ceiling) (236.1610)
- 8) Wall Mount Bracket (236.1865)
- 9) Fabric Wrap Clip (246.0650)

Installation Instructions (Cont.)

The Tumo Xcel Drapery Automation system has been designed for ease of installation. The mounting brackets will accommodate either wall or ceiling mount applications. Because building materials used in construction vary widely, BTX does not supply the fasteners. For safe installation we recommend to install a bracket no more than 20" from the next. Use more brackets with heavier fabrics. Installation steps are outlined below:

Ceiling Mount

I. Put the track mounting brackets onto the track.

The brackets for the end of the track should be mounted as close to the end as possible, normally 1cm/(3/8in) from the drive gear. Other brackets should be 20in(50cm) apart. See diagram below:

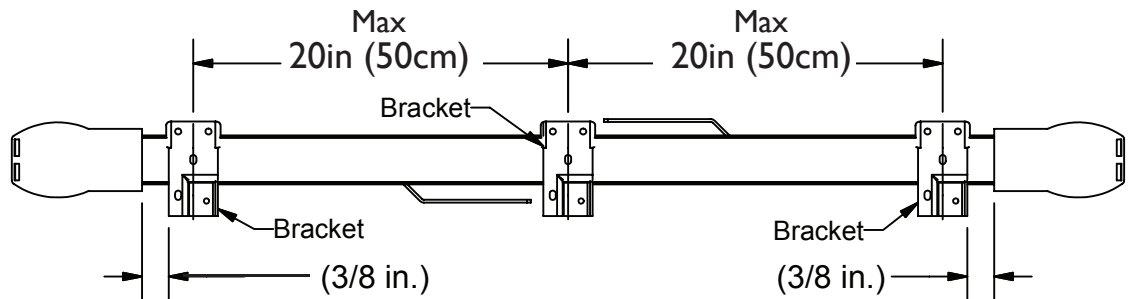

Loosen the screw on the bracket and move the locking arm to the open position. Position the brackets on the track as illustrated below (see diagram below left). Lock the bracket to the track by moving back the locking arm to locking position (see diagram below right) and tighten screw.

Note: If your track is spliced, make sure that you place a bracket on the left AND right side of the splice.

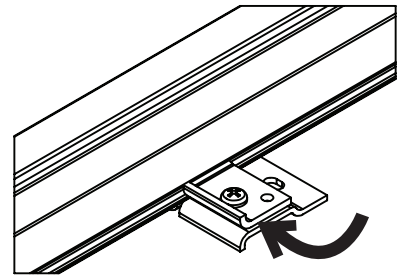
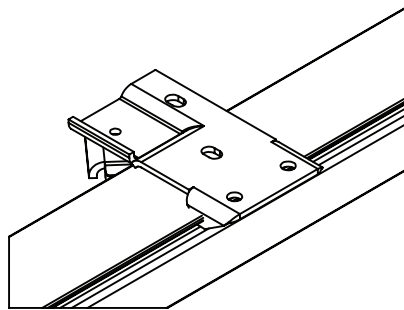

2. Install the fabric wrap clip.

Put the fabric wrap clip into the slot at the very end of the drive gear. See diagram below:

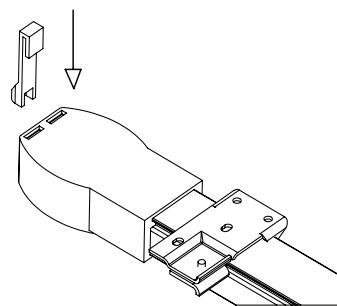

Note: Installers must provide the fasteners appropriate for the conditions at the particular job site. Install brackets onto firm and solid surfaces only. DO NOT install onto dry wall.

Installation Instructions (Cont.)

3. Install the track onto the ceiling.

After attaching the mounting brackets to the track, hold up the track to the position where the track should be located. Screw each bracket into solid blocking, using the available holes.

Warning: Do not apply load to sheetrock or soft materials!

4. Install the motor.

With the motor drive shaft upward, guide the shaft into the center hole of the drive gear, then push the motor up until it fits securely in the drive gear (see diagram below left). When the motor and drive gear are fully engaged, push the locking arm to the side until you hear a "click" sound (see diagram below right). The motor is now locked into place.

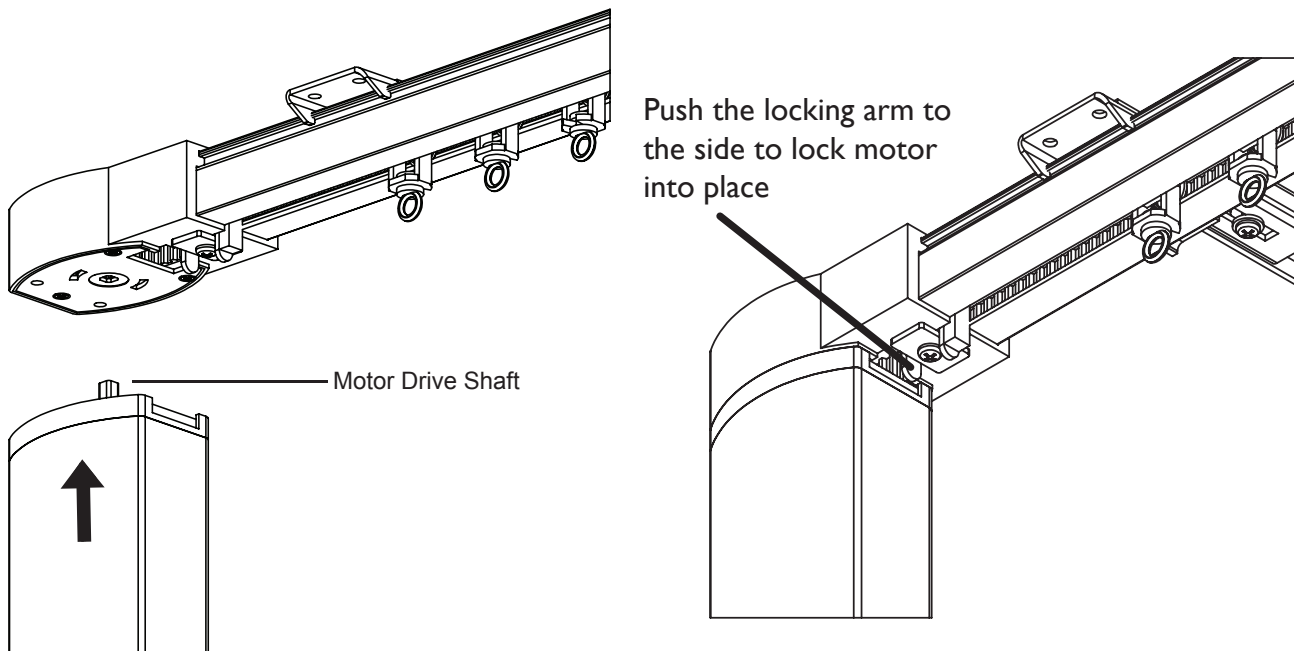

5. Connect the power supply to the motor.

Connect the power supply to the motor and plug the power supply into a wall outlet for power.

Installation Instructions (Cont.)

Wall Mount

1. Mount bracket to wall

Install the wall brackets to solid blocking no more than 20" apart, or closer as needed. **Be sure not to apply load to sheetrock or soft material!**

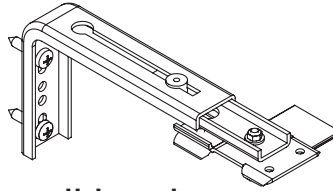

2. Mount the track to the wall brackets.

The brackets for the end of the track should be mounted as close to the end as possible, normally 3/8 in. from the drive gear. Other brackets should be no more than 20" apart. See diagram below:

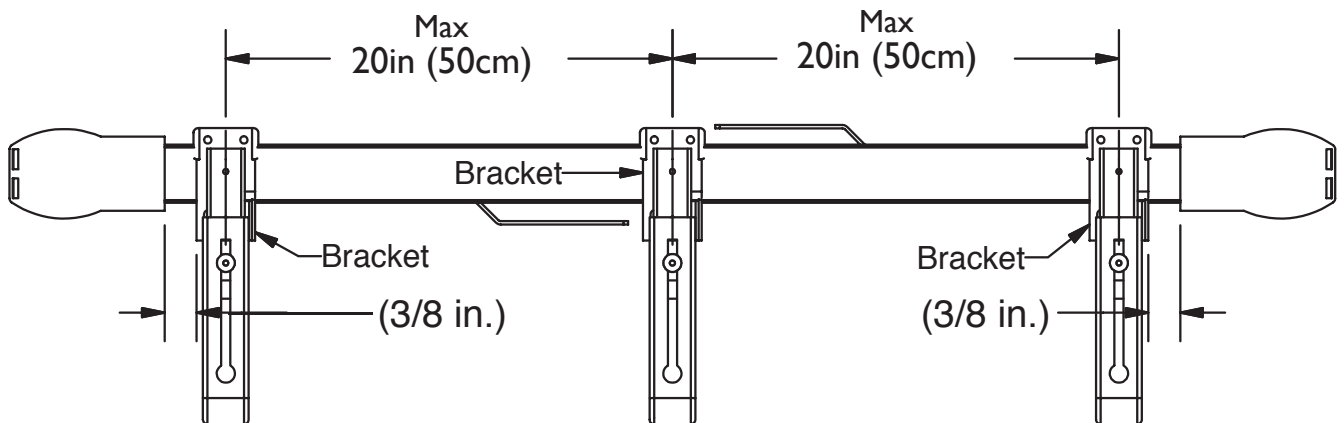

Loosen the screw on the bracket and move the locking arm to the open position. Position the track onto the brackets as illustrated below (see diagram below left), lock the track to the brackets by moving back the locking arm to locking position (see diagram below right) and tighten screw. **Note: If your track is spliced, make sure to place a bracket on the left AND right side of the splice.**

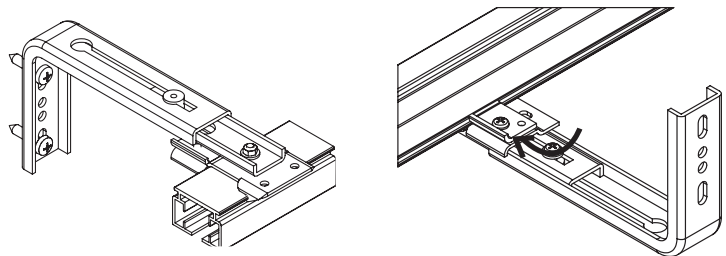

3. Install the fabric wrap clip.

Insert the fabric wrap clip into the slot at the very end of the drive gear. (see diagram below):

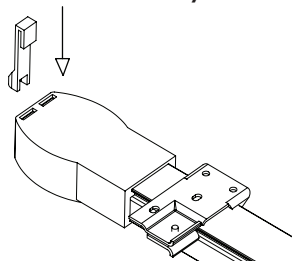

Installation Instructions (Cont.)

4. Install the motor.

With the motor drive shaft upward, guide the shaft into the center hole of the drive gear then push the motor up until it fits securely in the drive gear (see diagram below left). When the motor and drive gear are fully engaged, push the locking arm to the side until you hear a "click" sound (see diagram below right). The motor is now locked into place.

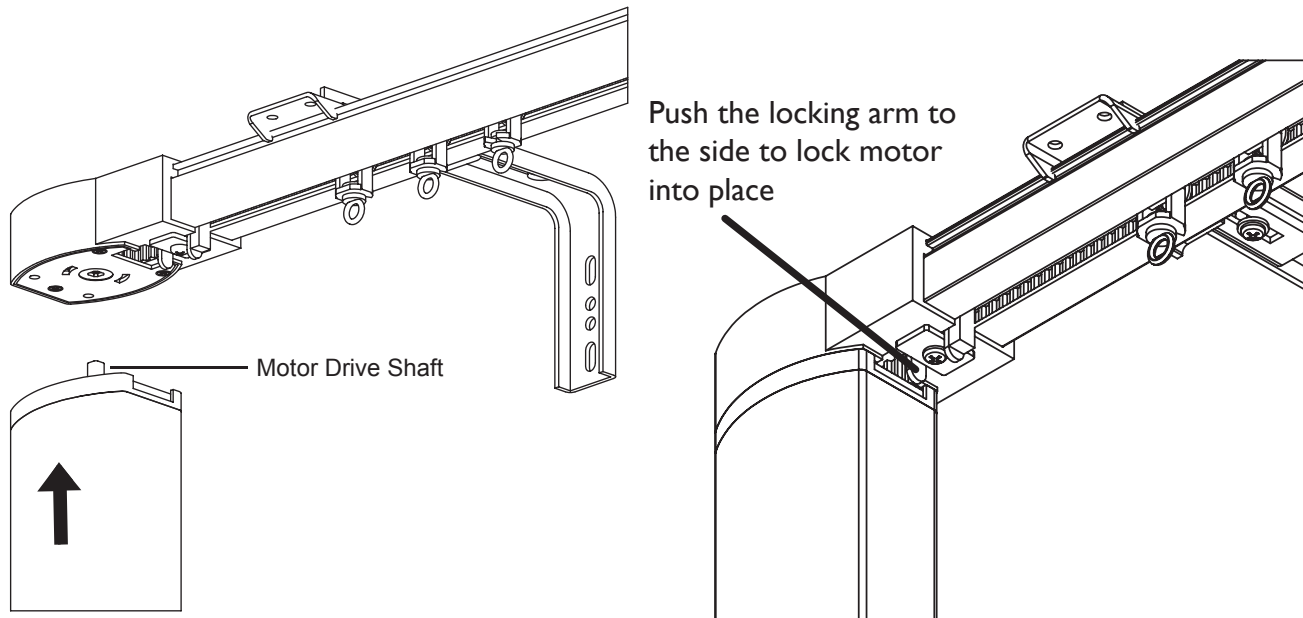

5. Connect the power adaptor to the motor.

Connect the power adaptor to the motor. Plug the power adaptor into a wall outlet for power.

6. Programming the handsender for one motor. (see picture on page 12)

Note: To put motor into program mode, unplug the motor for 30 seconds and then reconnect. The program mode is now engaged for the first three minutes the motor has been plugged in. When programming a new system, any Tumo systems within range that have been programmed within the last three minutes must be unplugged to prevent them from becoming reconfigured to match the new system. Each motor can learn up to four channels. To delete all channels from a programmed motor, make sure the motor is in program mode and press the STOP and DOWN buttons simultaneously .

The Tumo Xcel handsender can control up to 6 motors or 6 groups of motors. Before using the handsender, the motor needs to recognize the handsender. Put motor into program mode and press the channel selection button. This will light up the last channel that was selected. Press again and the next channel will be selected and light up, etc. Continue pressing the channel selection button until the channel you wish to program is selected and the corresponding channel number LED lights up, then press the stop button. Before the motor leaves program mode, press and hold the UP and DOWN buttons simultaneously. The selected channel number will light up with a slow flash. The track will then react with a movement to indicate that the motor is receiving the signal from the handsender and to confirm that communication between motor and handsender is established. Press the LEFT or RIGHT button, and the overlap arm of the drapery system should start to move. The channel has now been programmed.

Installation Instructions (Cont.)

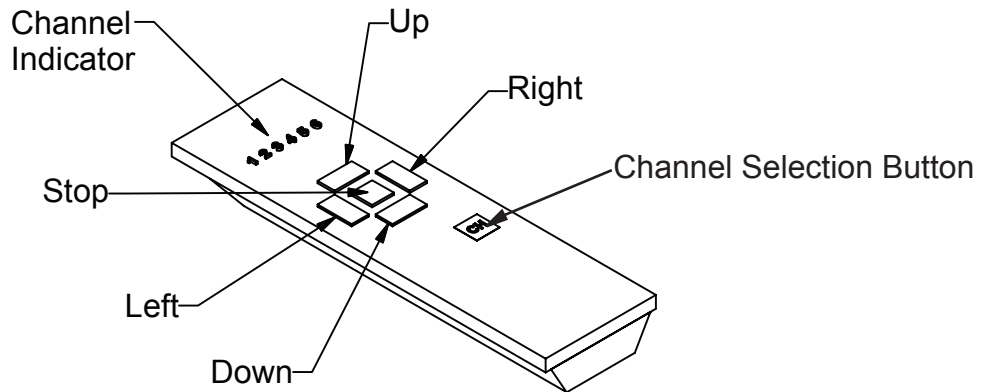

7. Programming one handsender to control multiple motors or multiple groups of motors.

Note: When programming a new system, any Tumo systems within range that have been programmed within the last three minutes must be unplugged to prevent them from becoming reconfigured to match the new system.

Select channel on the handsender (for example, channel 2) by repeatedly pressing the channel selection button until the "2" is lit. To program another motor to recognize this same channel(2) repeat the same programming procedure in step 6 for the new motor. Six motors can be programmed to be controlled by the same handsender this way. Select this channel to confirm that a particular motor has been programmed to communicate with this channel by pressing LEFT or RIGHT. You should see the system react. Continue this procedure until all six channel number LEDs light up. All the motors will now respond at the same time when you press the LEFT or RIGHT button. Any one of the six channels can be programmed this way for a group of motors. In this case, each channel will control all the motors in that group at the same time.

8. Connecting Tumo Xcel Drapery Systems to other controls

The Tumo Xcel Drapery System can be easily linked with most third-party control devices through the low-voltage connecting port at the bottom of the motor. This port can be used to connect to both local and network controls. BTX Supply can provide technical assistance upon request to meet your project needs. With the Tumo Xcel Drapery System, only a BTX low-voltage wall switch is needed to perform control operations. Simply connect the motor to a low-voltage switch by plugging one end of the provided RJ-11-4 lead into the low-voltage port on the motor. Plug the other end of the modular wire into the low-voltage port of the switch, and fix the wall switch at convenient position.

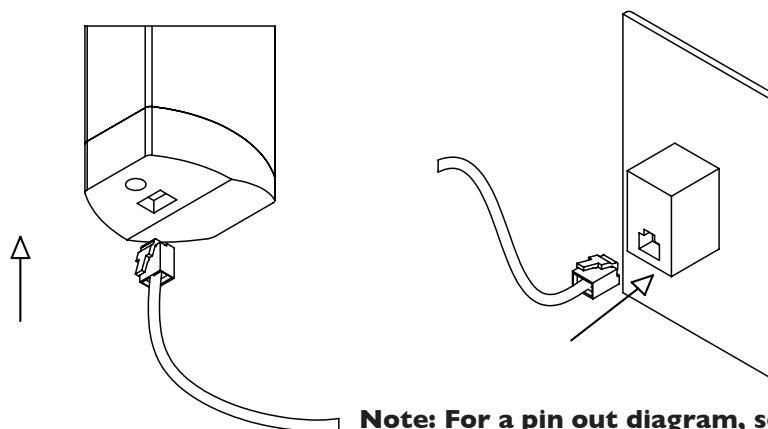

Note: For a pin out diagram, see page 14.

Additional Programming Instructions

Reverse Motor Direction

Once the system has been installed and the handsender has been programmed, the RIGHT and LEFT buttons should match the travel direction of the drapery when engaged to open or close. If the buttons do not match the travel direction of the system, you may choose to reverse the motor direction to match the buttons on the handsender. To change the motor direction, you will need to unplug the motor for one minute, then plug it back in. Press and hold the LEFT and RIGHT buttons simultaneously. The channel indication LED should flash slowly. When the change has taken place, the motor should react with a jog within 5 seconds. Give the system a test run to verify the change.

Delete Channel Settings at the Motor

Using the CHANNEL SELECTION button, select the channel programmed to the motor for which you wish to cancel the channel setting. Press and hold the UP and STOP buttons until the motor reacts with a jog. This channel setting has now been deleted from the motor. If you now press or hold any of the directional buttons, the motor should not move.

Replacing the Handsender Battery

The handsender is powered by two lithium-ion button batteries, model number: CR24300. This battery style is fairly common and should be easy to find at most retail stores that sell electronic equipment or accessories. The battery will last for over two years under normal conditions. When the channel LED numbers one and six are lit up at the same time, this means the batteries are almost dead and need to be replaced. Open the handsender case with both hands by twisting the top edge of the handsender until the entire front cover pops off. The cover may be a little tight to remove. When inserting the new batteries, be sure to place the positive side down. After inserting the new batteries, replace the cover, and the handsender will be ready for use.

Operating the Tumo Xcel Drapery System

Upon completion of the hardware installation, programming of the handsender and installation of the drapery fabric, the system is ready for long term, reliable operation. The handsender open and close directions are indicated by the arrows, left for open and right for close (or vice versa if desired).

It is not necessary to point the RF handsender in a specific direction. The motor receives the signal within a 30ft-50ft range. If more than one track is to be controlled by the handsender, use the channel selection button as described under section 7 on the previous page. Clear open and close signs are on the optional wall switch. At any time, the drapes can be operated manually instead of by handsender or wall switch.

Low-voltage Control Port

for switch control or audio/video, lighting control and building management systems

Front View of 4P4C RJ (RJ 11/4) Connector

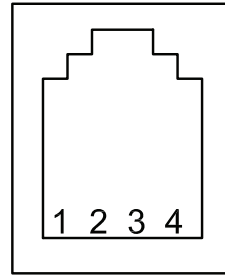

- 1. A
- 2. B
- 3. +5V
- 4. Common

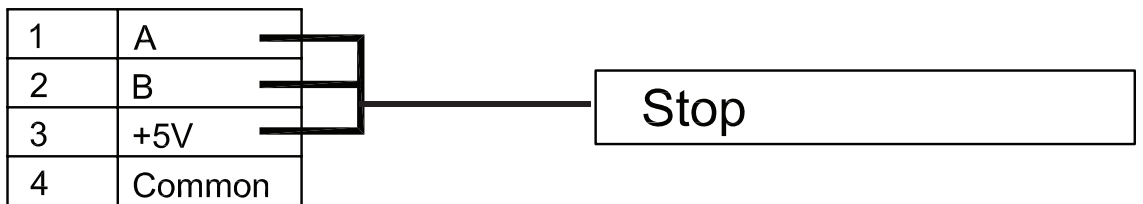
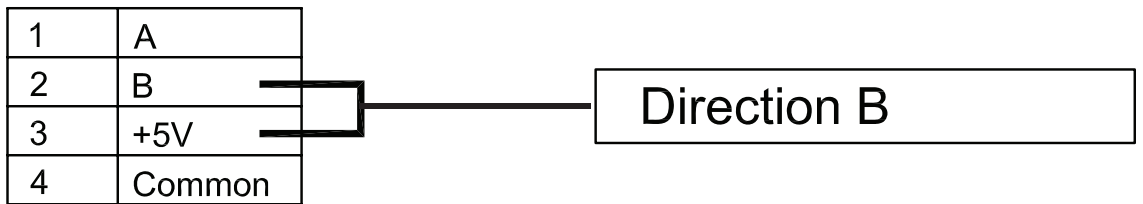
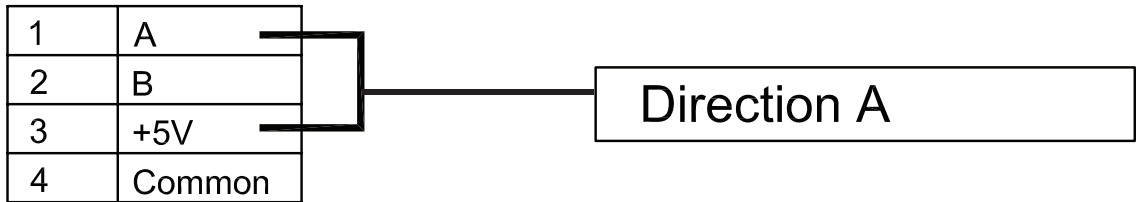

Warranty/Terms & Conditions

1. Contract

All offers, quotes and sales by BTX Window Automation, Inc. (BTX) are subject to these Terms and Conditions of Sale. No other agreements have been made or will be valid unless expressly confirmed in writing by BTX.

2. ACCEPTANCE

BY TAKING DELIVERY OF BTX PRODUCTS, PURCHASER ASSENTS TO THE TERMS AND CONDITIONS STATED HEREIN, UNLESS OTHERWISE EXPRESSLY AGREED IN WRITING BY BTX. BTX HEREBY OBJECTS TO ANY DIFFERENT OR ADDITIONAL TERMS AND CONDITIONS WHICH MAY BE PROPOSED OR HAVE BEEN PROPOSED BY PURCHASER IN ANY PURCHASE ORDER FORMS OR OTHER DOCUMENTS. THE TERMS AND CONDITIONS STATED HEREIN SHALL PREVAIL OVER ANY DIFFERENT OR ADDITIONAL TERMS AND CONDITIONS PROPOSED BY PURCHASER AND SHALL APPLY TO THE SALE OR SHIPMENT OF ANY GOODS IN RESPONSE TO PURCHASER'S ORDER.

3. Prices and Delivery

All quoted prices are valid for a period of 60 days from the date of issue, unless otherwise agreed by BTX in writing. Prices on accepted orders remain firm for a period of four months from the date of order acceptance, provided final delivery occurs within that period. If delivery is to occur more than four months from the date of order acceptance, prices are subject to change in accordance with any changes in the published BTX price list which occur after the date of order acceptance. All prices quoted are FOB Dallas, excluding all freight, packaging and taxes. All delivery dates are approximate.

4. Payment Terms

(a) Open account payment terms may be established from time to time at the sole discretion of BTX, and are subject to credit approval in writing. Terms on open accounts are payment in full, net 30 days from date of invoice. Payment terms for single transactions and transactions other than on open account are net C.O.D. or prepay unless confirmed otherwise in writing by BTX.

(b) Amounts past due are subject to a finance charge of 1.5% per month to the legal limit, and the finance charge will apply without further prior notice. In case of purchaser's delinquency in payment or insolvency, BTX retains the right to halt or interrupt all further deliveries and service to the purchaser until all past due amounts have been paid, and to require payment in advance for orders not yet delivered, without any liability resulting for BTX. Purchaser expressly agrees to indemnify BTX and hold BTX harmless from all charges and liability which might arise in any manner from purchaser's nonpayment.

5. Inspection, Acceptance and Claims

All claims by purchaser against BTX for shortages must be made in writing to BTX within fourteen days from date of shipment from BTX's Dallas base or they are waived. Any claims for transport damage are the responsibility of the recipient and must therefore be filed with the carrier by the recipient.

6. Risk of Loss

Full risk of loss, damage or destruction of the goods shall pass to purchaser upon delivery of the goods to the carrier at the point of shipment or upon delivery at storage, whichever applies.

7. Force Majeure

If an order cannot be completed due to causes beyond BTX's control, BTX retains the right to either cancel the uncompleted portion of the order or complete the order if and when this becomes possible. Purchaser shall not have the right to withhold payment on delivered goods and/or services, nor to unilaterally change the order or cancel same. Force majeure includes but is not limited to strikes, lock-outs, storms, floods and the like, terrorism, wars, revolutions, major equipment failures or fire damage at production facilities, etc.

8. Warranty

BTX extends a five-year limited warranty for its Tumo™ DC systems and controls. BTX warrants its other systems and 110/220V motors and hardware accessories against defects in material and workmanship for a period of five years from date of shipment from BTX's Dallas base; however, pull chains and cords for roller shades are excluded. BTX controls and electric and electronic components carry a one-year warranty against defects in material and workmanship from date of shipment from BTX's Dallas base. BTX does not warrant cords and tapes for lift systems, nor customer's own materials, and BTX disclaims any written, oral or implied warranties for such materials. If any item to which a warranty applies proves to be defective during the specified warranty period under normal and proper use and provided the equipment or part has been properly stored, installed and maintained with due regard to any directives, instructions and operating procedures provided, BTX shall, upon presentation of proof of purchase, repair or replace the item at the sole option of BTX, F.O.B. Dallas. Application of the warranty will be determined by BTX technical staff after return of the item, its inspection and any necessary investigation. This warranty does not apply in case of defects resulting from faulty installation, misuse, misapplication, abuse, mishandling, shipping or failure to follow instructions. This warranty does not cover any incidental, special or consequential damages, labor on location, service calls, reinstallation, or expenses involved in shipping, packing, and returning the

goods. It also does not cover damages caused by fire, flood, or act of God. BTX warrants items repaired or replaced pursuant to the above warranty, under normal and proper use, storage, installation and maintenance, against defects in material and workmanship for a period of 30 days from date of start-up of such repaired or replaced item or the expiration of the original warranty, whichever is longer. Correction of non conformities in the manner and for the period of time specified herein shall be purchaser's exclusive remedy and shall constitute fulfillment of all liabilities of BTX, whether in warranty, contract, negligence, tort, or otherwise with respect to the item delivered. In no event shall BTX be responsible for providing access to the allegedly defective item or for disassembly or reinstallation of such item or parts.

9. DISCLAIMER

THE FOREGOING EXPRESS WARRANTIES ARE EXCLUSIVE AND IN LIEU OF ALL OTHER WARRANTIES, WRITTEN, ORAL OR IMPLIED. ALL OTHER WARRANTIES, INCLUDING ANY WARRANTY OF MERCHANTABILITY OR FITNESS FOR A PARTICULAR PURPOSE, ARE HEREBY DISCLAIMED.

10. LIMITED LIABILITY

BTX'S LIABILITY FOR ANY AND ALL CLAIMS, CHARGES, EXPENSES, DAMAGES, LOSSES AND INJURIES ARISING OUT OF OR RELATING TO ITS PERFORMANCE OR BREACH OF ANY AGREEMENT OF SALE FOR GOODS AND/OR THE MANUFACTURE, SALE, DELIVERY, RESALE, REPAIR OR USE OF ANY GOODS SHALL NOT EXCEED THE PURCHASE PRICE OF SUCH GOODS, REGARDLESS WHETHER THE CLAIM IS BASED ON CONTRACT, TORT, NEGLIGENCE, STATUTE, STRICT LIABILITY, WILLFUL OR WANTON CONDUCT, WARRANTY (EXPRESS OR IMPLIED), OR OTHERWISE. THIS SHALL BE PURCHASER'S SOLE AND EXCLUSIVE REMEDY AGAINST BTX OTHER THAN THE REMEDY PROVIDED FOR UNDER THE EXPRESS BTX WARRANTIES. IN NO EVENT SHALL BTX BE LIABLE FOR INCIDENTAL, SPECIAL, CONSEQUENTIAL OR EXEMPLARY DAMAGES.

11. ARBITRATION

BTX AND PURCHASER AGREE THAT THIS TRANSACTION INVOLVES INTERSTATE COMMERCE AND THAT AT THE OPTION OF BTX, ANY DISPUTE RELATING TO IT IN ANY MANNER SHALL BE SUBMITTED TO BINDING ARBITRATION BEFORE THE AMERICAN ARBITRATION ASSOCIATION AND SHALL BE GOVERNED BY THE FEDERAL ARBITRATION ACT OR, IF THAT STATUTE IS INAPPLICABLE, ANY DISPUTE SHALL BE GOVERNED BY THE TEXAS ARBITRATION ACT; HOWEVER, NO ARBITRATOR MAY AWARD PUNITIVE DAMAGES. PURCHASER AGREES TO PAY ALL COSTS INCURRED BY BTX, INCLUDING BUT NOT LIMITED TO COSTS OF ARBITRATION, COLLECTION, REASONABLE ATTORNEY'S FEES, EXPENSES AND ANY COURT COSTS.

12. Return

No goods may be returned without the express written approval of BTX and the receipt of an BTX RGA identification number. Goods approved for return must be returned in original packaging, freight prepaid, clearly marked with the BTX RGA identification number and be accompanied by a copy of the original invoice. Application of the warranty will be determined by BTX technical staff after return of the item, its inspection, and any necessary investigation. A restocking charge of 25% of invoice value will apply on all items accepted for return.

13. Liens and Security Interest

Purchaser will not permit to be created or to remain undischarged any lien, encumbrance or charge upon the goods supplied by BTX until BTX has received payment in full for such goods. If any liens, encumbrances or charges shall be filed against BTX goods prior to payment in full, purchaser shall discharge the liens, encumbrances or charges within ten days and reimburse BTX for expenses incurred in defending its security interest. Title to the goods shall remain with BTX until payment in full has been received.

14. Statute of Limitations

Any action against BTX shall be commenced within one year after the cause of action has arisen.

15. Choice of Law and Venue

The rights and duties of the parties hereunder and the construction and effect of these terms and conditions shall be governed by the laws of the State of Texas. Venue shall lie in Dallas, Texas, to the exclusion of any other jurisdiction.

16. This agreement supersedes any inconsistent or additional promises made by any employee, representative, agent or dealer of BTX.

17. If any part of this agreement is found invalid, the balance of the agreement remains enforceable.

071508



BTX[®]
10763 Sanden Drive • Dallas, TX 75238
(214) 340-2800 • 1-800-422-8839 • FAX (214) 343-2252
www.btxinc.com • btxwindow@btxinc.com